

32

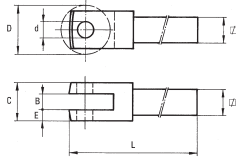

KNURLING

Conventional knurling roll holder for knurling by deformation

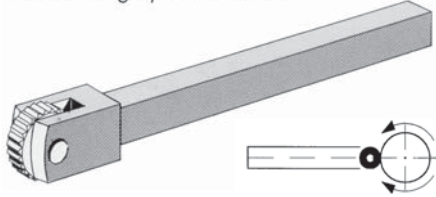

RASN						
∅	C	E	L	D min-max	B	d
7	8	2	120	8	4	3
8	8	2	120	8	4	3
7	10	3	120	10-15	4	4
8	10	3	120	10-15	4	4
10	10	3	120	10-15	4	4
8	12	3,5	120	15	5	5
10	12	3,5	120	15	5	5
12	12	3,5	120	15	5	5
10	16	4	160	20	8	6
12	16	4	160	20	8	6
12	20	5	160	20	10	6
20	20	5	160	20	10	6

Rolls for Knurling



D	B	d	* Available pitches																	
			0,3	0,4	0,5	0,6	0,7	0,8	1,0	1,2	1,5	1,75	2,0							
8	3	3	*	*	*	*	*	*	*	*	*	*	*	*	*	*	*	*	*	*
8	4	3	*	*	*	*	*	*	*	*	*	*	*	*	*	*	*	*	*	*
10	3	3	*	*	*	*	*	*	*	*	*	*	*	*	*	*	*	*	*	*
10	4	3	*	*	*	*	*	*	*	*	*	*	*	*	*	*	*	*	*	*
10	4	4	*	*	*	*	*	*	*	*	*	*	*	*	*	*	*	*	*	*
12	4	4	*	*	*	*	*	*	*	*	*	*	*	*	*	*	*	*	*	*
15	4	4	*	*	*	*	*	*	*	*	*	*	*	*	*	*	*	*	*	*
15	5	4	*	*	*	*	*	*	*	*	*	*	*	*	*	*	*	*	*	*
15	5	5	*	*	*	*	*	*	*	*	*	*	*	*	*	*	*	*	*	*
15	6	4	*	*	*	*	*	*	*	*	*	*	*	*	*	*	*	*	*	*
15	6	5	*	*	*	*	*	*	*	*	*	*	*	*	*	*	*	*	*	*
20	6	6	*	*	*	*	*	*	*	*	*	*	*	*	*	*	*	*	*	*
20	8	6	*	*	*	*	*	*	*	*	*	*	*	*	*	*	*	*	*	*
20	10	6	*	*	*	*	*	*	*	*	*	*	*	*	*	*	*	*	*	*

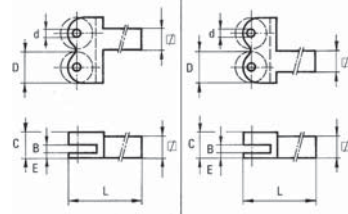
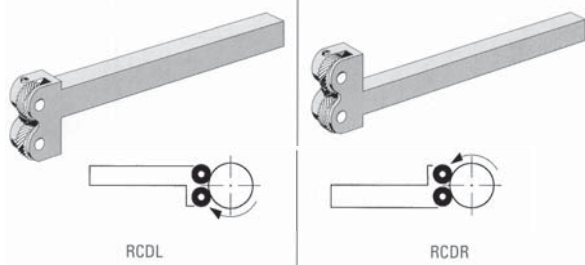

∅	C	E	D	B	d	RCDL	RCDR
						L	L
6	10	1,5	8	3	3	120	-
7	10	1,5	8	3	3	120	-
7	11	1,5	8	4	3	120	-
8	10	1,5	8	3	3	135	120
8	10	1,5	10	3	3	135	120
8	12	1,5	8	4	3	135	-
10	10	1,5	8	3	3	135	120
10	10	1,5	10	3	3	135	120
10	12	1,5	8	4	3	135	120
10	12	2,0	10	4	3	135	120
10	12	2,0	10	4	4	135	120
12	12	2,0	10	4	4	150	120
12	12	2,0	15	4	4	-	120
12	12	2,0	15	5	4	-	120
12	12	2,0	15	5	5	-	120
16	16	2,0	15	4	4	-	120
16	16	2,0	15	5	4	-	120
16	16	2,0	15	5	5	-	120
16	16	2,0	15	6	4	-	120
20	20	2,0	15	4	4	-	120
20	20	2,0	15	5	4	-	120
20	20	2,0	15	6	4	-	120
20	20	2,0	20	6	6	-	120
20	20	2,0	20	8	6	-	120

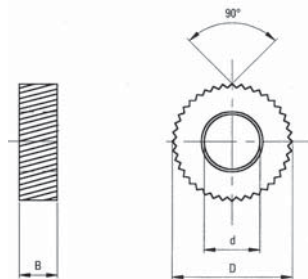



KNURLING

STRAIGHT KNURL

This pattern corresponds with DIN 82, section knurl RAA and is produced with all QUICK models FL, STR and STABIL. These tools require knurling cutters with a 30° spiral.

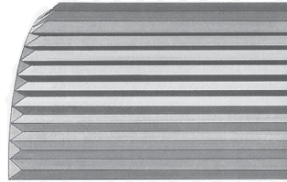
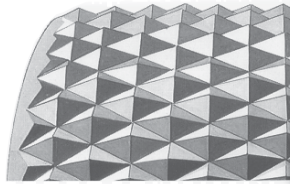

DIAMOND KNURL

This pattern corresponds with DIN 82, section RGE. It crosses at an angle of 30° to the center axis. Diamond knurls are produced with QUICK models KF, STR, STABIL and require straight knurling cutters.

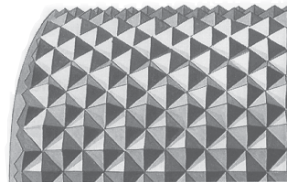

CROSS KNURL

This pattern crosses at a 45° angle to the center axis and therefore does not correspond with DIN 82, section RKE. Cross knurls are cut with QUICK Models KF, STR, STABIL and require cutters with a 15° spiral.

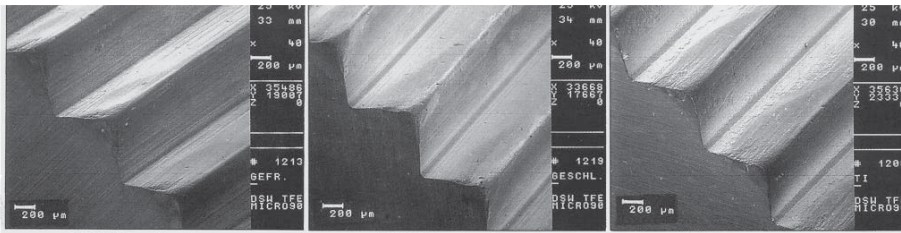

QUICK Knurling Cutter milled HRC 63.5

QUICK Knurling Cutter ground HRC 63.5

QUICK Knurling Cutter ground and TIN-coated HRC 63.5

The above 3 illustrations clearly demonstrates the difference between milled, ground and ground + TIN coated Knurling Cutters. They are based on the following test example:

MACHINING DATA: Material CK 45 759 N/mm² Pitch of knurl: 1.0 mm Surface speed: v = 43 m per minute/min
Actual knurling time: 150 minutes Feed: 0.21 mm per revolution

QUICK KNURLING CUTTERS AVAILABLE SIZES AND PITCHES EITHER WITH MILLED TEETH, GROUND TEETH, OR GROUND + TIN COATED TEETH		
DIAMETER	TOOTH ANGLE	AVAILABLE PITCHES
8.9 mm	90° Straight cut	0.3 - 0.4 - 0.5 - 0.6 - 0.8 - 1.0
8.9 mm	15° L (left hand spiral)	0.3 - 0.4 - 0.5 - 0.6 - 0.8 - 1.0
8.9 mm	15° R (right hand spiral)	0.3 - 0.4 - 0.5 - 0.6 - 0.8 - 1.0
8.9 mm	30° L (left hand spiral)	0.3 - 0.4 - 0.5 - 0.6 - 0.8 - 1.0
8.9 mm	30° R (right hand spiral)	0.3 - 0.4 - 0.5 - 0.6 - 0.8 - 1.0
14.5 mm	90° Straight cut	0.4 - 0.5 - 0.6 - 0.8 - 1.0 - 1.2
14.5 mm	15° L (left hand spiral)	0.4 - 0.5 - 0.6 - 0.8 - 1.0 - 1.2
14.5 mm	15° R (right hand spiral)	0.4 - 0.5 - 0.6 - 0.8 - 1.0 - 1.2
14.5 mm	30° L (left hand spiral)	0.4 - 0.5 - 0.6 - 0.8 - 1.0 - 1.2
14.5 mm	30° R (right hand spiral)	0.4 - 0.5 - 0.6 - 0.8 - 1.0 - 1.2
21.5 mm	90° Straight cut	0.4 - 0.5 - 0.6 - 0.8 - 1.0 - 1.2 - 1.5 - 1.6 - 2.0
21.5 mm	15° L (left hand spiral)	0.4 - 0.5 - 0.6 - 0.8 - 1.0 - 1.2 - 1.5 - 1.6 - 2.0
21.5 mm	15° R (right hand spiral)	0.4 - 0.5 - 0.6 - 0.8 - 1.0 - 1.2 - 1.5 - 1.6 - 2.0
21.5 mm	30° L (left hand spiral)	0.4 - 0.5 - 0.6 - 0.8 - 1.0 - 1.2 - 1.5 - 1.6 - 2.0
21.5 mm	30° R (right hand spiral)	0.4 - 0.5 - 0.6 - 0.8 - 1.0 - 1.2 - 1.5 - 1.6 - 2.0

KNURLING



Cross knurl RKE:
1 pc. knurling wheel 15°L
1 pc. knurling wheel 15°R



Diamond knurl RGE:
2 pcs. knurling wheels 90°

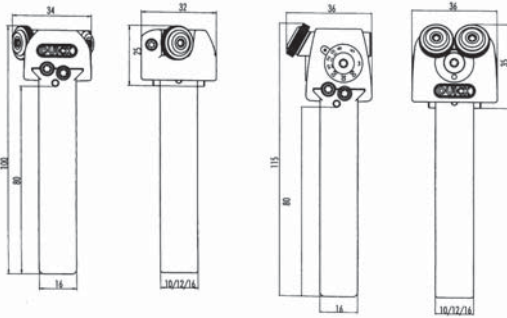
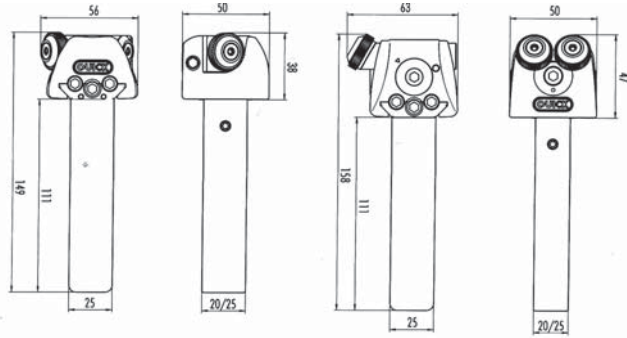

KNURL TYPES



Straight knurl RAA:
right hand tool
1 pc. knurling wheel 30°R
left hand tool
1 pc. knurling wheel 30°L



Spiral knurl RBR:
right hand tool
1 pc. knurling wheel 15°R
1 pc. knurling wheel 90°



Spiral knurl RBL:
left hand tool
1 pc. knurling wheel 15°L
1 pc. knurling wheel 90°



LA/KF

Technical data:

Knurling pattern: Cross and diamond
Working range: 1.5–12 mm Ø
(0.060–0.472")
Available shank: 6x6 (0.240")
7x7 (0.280")
8x8 (0.320")
10x10 (0.390")
12x12 (0.470")
Length of shank: Approx. 80 mm (3.150")

Knurling cutter:
8.9 mm Ø (0.350") (11/32")
Cross: 1 pc. 15° right hand spiral
1 pc. 15° left hand spiral
Diamond: 2 pcs. 90° straight cut.
Available Pitches (teeth per inch):
0.3 mm (85) 0.4 mm (63) 0.5 mm (51)
0.6 mm (42) 0.8 mm (32) 1.0 mm (25)
Weight of tool: Approx. 140 grams.

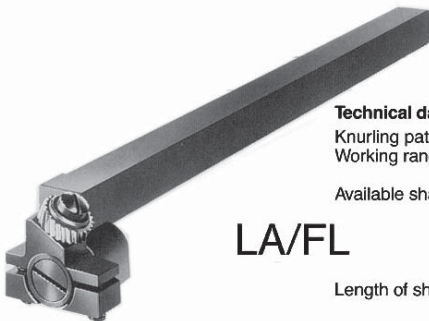

LA/FL

Technical data:

Knurling pattern: Straight
Working range: 1.5–12 mm Ø
(0.060–0.472")
Available shank: 6x6 (0.240")
7x7 (0.280")
8x8 (0.320")
10x10 (0.390")
12x12 (0.470")
Length of shank: Approx. 80 mm
(3.150")

Knurling cutter:
8.9 mm Ø (0.350") (11/32")
1 pc. 30° left hand spiral for left hand cutting
and 30° right hand spiral for right hand cutting tools.
Available Pitches (teeth per inch):
0.3 mm (85) 0.4 mm (63) 0.5 mm (51)
0.6 mm (42) 0.8 mm (32) 1.0 mm (25)
Weight of tool: Approx. 110 grams.

40



KNURLING



The chameleon of knurling tools.

- P669-0200** A1/KF shank 10
- P669-0201** A1/KF shank 12
- P669-0202** A1/KF shank 16
- P669-0203** A1/FL shank 10
- P669-0204** A1/FL shank 12
- P669-0205** A1/FL shank 16



P669-0206 Set A1
consisting of:
A1/KF shank 16
A1/FL shank 12
shank 10

TECHNICAL DATA

Model	A1/FL - A1/KF
for workpiece \varnothing	3-50 mm
for pitches	0,4-1,2 mm
knurling wheel \varnothing	14,5 mm
shank \varnothing	10, 12 or 16 mm
shanklength	80 mm

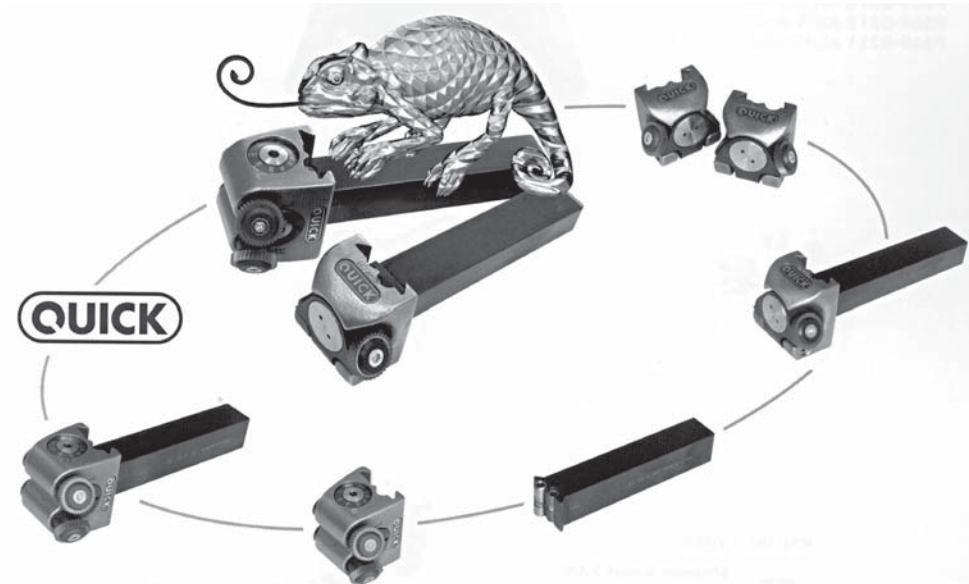

The chameleon of knurling tools.

- P669-0212** A2/FL shank 20
- P669-0210** A2/KF shank 20
- P669-0213** A2/FL shank 25
- P669-0211** A2/KF shank 25



P669-0214 Set A2
consisting of:
A2/KF shank 25
A2/FL shank 20

TECHNICAL DATA

Model	A2/FL - A2/KF
for workpiece \varnothing	5-250 mm
for pitches	0,4-2,0 mm
knurling wheel \varnothing	21,5 mm
shank \varnothing	20 or 25 mm
shanklength	110 mm